

# structural joint entirely in aluminium

## jointec™ GA

Sliding structural expansion joint entirely realised in aluminium. Designed to bear structural movements of large sized buildings or compounds of buildings. They are installed over the spaces existing between two semi-detached parts of a building of smaller entity or between different beam bays. They can connect and close these inter-spaces adjusting themselves up-wards, downwards and even transversally, according to the shrinkage-settlement movements of the whole building, either cyclic or permanent. Within the flooring bays frame created with the structural joints, a further surface subdivision with a suitable pattern of movement / expansion joints should be always provided for. See relevant indications on page 167.

Illustrated scale dimension 1:2

### INSTALLATION:

- Pre-assembled joint with metal brackets only to be removed after having properly fastened the joint to the sub-floor.
- Fasten the lateral flanges into the substrate with suitable fixing plugs (7 each linear meter, i.e. one every 30 cm, proceeding parallel on the two sides).
- Lay then the screed over the structural joint flanges and tile as normal.

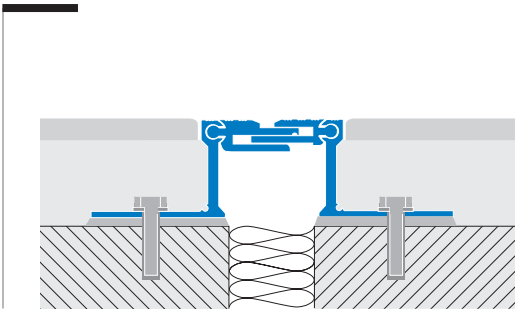

### JOINTEC GA-AN Natural Aluminium 74 mm width - gap 54 mm

Extruded aluminium profile. Good mechanical and chemical resistance over time. For outdoor utilization the similar joint type Jointec GM in brass is advisable.

Material: Extruded Natural Aluminium

Length: 4,00 metres

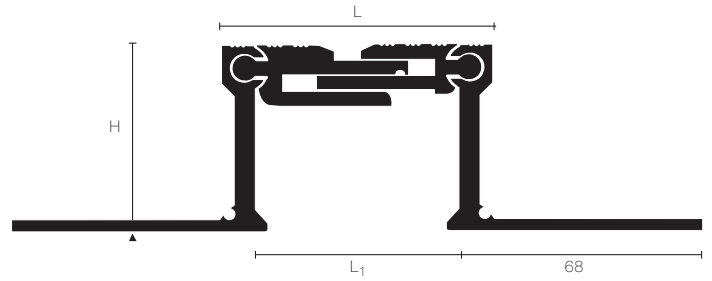

H=mm	L=mm	L <sub>1</sub> =mm	Finish	Art.
20	74	54	Natural Aluminium	GA 200 AN
50	74	54	Natural Aluminium	GA 500 AN
70	74	54	Natural Aluminium	GA 700 AN